

TFL 201: Frost-protection monitor/limiter with capillary-tube sensor

How energy efficiency is improved

Demand-led, large-scale monitoring of installation parts as required, without auxiliary energy.

Areas of application

Temperature monitoring in air heaters, water pipes and air ducting. Especially suitable for compact applications.

Features

- Temperature range: -5 to $+15$ °C
- Contact rating: 4 mA, 6 V to 10 A, 250 V
- Gold-plated silver contacts
- Switching point and switching difference can be adjusted
- Sealable
- 2 s time constant in water at 0.5 m/s
- 1.5, 3 or 6 m copper capillary tube

Technical description

- Transparent cover made of impact-resistant thermoplastic
- Ambient temperature: -5 to $+70$ °C
- IP 65
- Active from 10 cm capillary length in switching temperature
- Standard housing-mounted plug with cable connector for cables of 6 to 10 mm in diameter



T08904

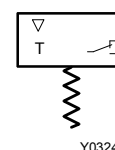

Y03243

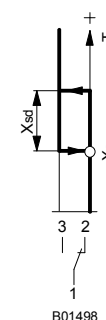

B01498

Type	Function	Setting range °C	Switching difference (Average values) K	Permissible sensor temp. °C	Weight kg
TFL 201 F001	X_{sd} = fixed	$-5...15$	2.0	$-20...200$	0.47
TFL 201 F011	X_{sd} = variable	$-5...15$	2...6	$-20...200$	0.47
TFL 201 F021	limiter	$-5...15$	2.0	$-20...200$	0.47
Contact rating as silver contacts ¹⁾	10(4) A, 250 V~ 50 W, 250 V=	Factory setting		5 °C	
min.	100 mA, 24 V	Tolerance of switching difference		max. ± 1 K	
as gold contacts ²⁾	160 mA, 50 V	Perm. temp. at head of instrument ⁴⁾		$-5...70$ °C	
min.	4 mA, 6 V	Degree of protection		IP 65 (EN 60529)	
Time constant		Protection class		I (IEC 60730)	
in air 0.3 m/s	35 s	Wiring diagram	monitor	A01497	
in water 0.5 m/s	2 s		limiter	A05218	
Active length of capillary tube ³⁾	min. 10 cm	Dimension drawing		M09981	
		Fitting instructions		MV 505752	
		Declaration on materials		MD 22.030	

Variants (otherwise as standard version)

TFL 201 F101 Capillary tube, 1.5 m long; with 3 holders, X_{sd} = fixed

TFL 201 F601 Capillary tube, 6.0 m long; with 5 holders, X_{sd} = fixed

Accessories

0296936 000* Bracket for rail: top-hat rail EN 50022, 35×7.5 or 35×15

0303167 000* Five additional holders for capillary tube

*) Dimension drawing or wiring diagram are available under the same number

- 1) If under inductive load, take RC circuit into account.
- 2) If the contacts are ever loaded higher than 160 mA, 50 V, the gold plating will be damaged. The contacts are then classed only as silver contacts, since they lose the characteristics of gold contacts.
- 3) The monitor always reacts to the coldest place (minimum length is 10 cm).
- 4) The head of the instrument must be fitted at a place which is warmer than that of the sensor.

Operation

Normally, contacts 1-3 are closed. Whenever the temperature falls below the lower switching point (set value), the contacts switch over from 1-3 to 1-2. When the temperature exceeds the upper switching point, the contacts switch back from 1-2 to 1-3.

F021 limiter with mechanical lock

When the temperature has again risen by the switching difference X_{sd} , the contacts can be reset manually from 1-2 to 1-3 (reset button).

Explanation of type codes

F	X (Capillary tube)	Y (Function)	1
	0 = 3 m 1 = 1.5 m 6 = 6 m	0 = X_{sd} = fixed 1 = X_{sd} = variable 2 = limiter	

Additional technical data

CE conformity complies with: Directive 2006/95/EC EMC Directive 2004/108/EC	EN 60730-1/ EN 60730-2-9 EN 61000-6-1/ EN 61000-6-2 EN 61000-6-3/ EN 61000-6-4
---	--

Technical notes

RC circuit under inductive load

For the optimum RC circuitry, refer to the specifications supplied by the manufacturers of the relays, contactors etc. If these are not available, the inductive load can be reduced by applying the following rule of thumb (not binding):

- Capacity of the RC circuitry (μF) \geq operating current (A)
- Resistance of the RC circuitry (Ω) \approx coil resistance (Ω)

Influence on switching difference

The switching difference is slightly dependent on the setpoint. The switching differences stated in the PDS sheet are typical values at the start of the range. The setpoint's influence on the switching difference increases the switching difference by: $\Delta X_{sd} = (\text{setpoint } X_S - \text{start of range}) \times 0.04$

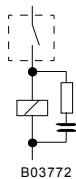

Wiring diagram

Monitor

Limiter

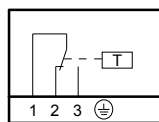

A01497a

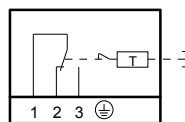

A05218a

Dimension drawing

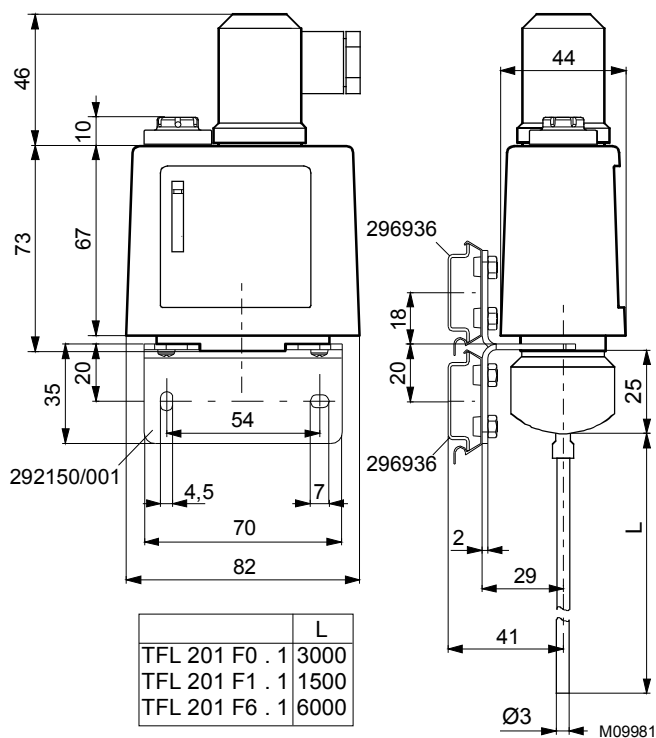

Accessories

