

EYB 270: Room operating panel for ecos intelligent unitary controllers

For use as a temperature sensor and for operating an intelligent unitary controller of the type *ecos* EYE 200 to EYE 206.

Front plate (220 × 82 mm) of aluminium, with 12 buttons and clear LCD showing setpoint correction, display of actual value, room occupancy, fan speeds, window contacts and dew-point alert. Plug-in cable terminals (3 × 1.5 mm²). The button symbols can be adapted to the project by using insertable labels. The F101 variant has a yellow, permanently-lit LED to illuminate the lighting buttons, plus an additional cable terminal for the LCD setpoint indicator.



Type	Continuous LED	Setpoint indicator	Room occupancy	Fan speeds	Power supply	Weight [kg]
EYB 270 F001	no	no	0/1	0-auto-1-2-3	via EYE	0.1
EYB 270 F101	yes	yes	0/1	0-auto-1-2-3	via EYE	0.1

Temperature sensor (LCD)	0...35 °C	Ambient temperature	0...45 °C
Resolution	0.1 K	Ambient humidity	< 85 %rh
Time constant	13 min		without condensation
Setpoint indication (LCD)	0..10 V = 16...25.5 °C	Ambient class	IEC 60721 3K3
Resolution	0.1 K	Protection class	III
Connection	3-wire (4-wire)	Degree of protection	IP 30 (EN 60529)
Max. length of cable	100 m	Wiring diagram	A07045
Setpoint correction	variable	Dimension drawing	M09475
		Fitting instructions	MV 505660
		Complies with:-	
		EMC directive 89/336/EEC	EN 61000-6-1/ EN 61000-6-2 EN 61000-6-3/ EN 61000-6-4

Accessories

0382126 001* Junction box (three-way) for recessed fitting

*) Dimension drawing or wiring diagram are available under the same number

Addresses (MFA) of the EYB 270 data points.

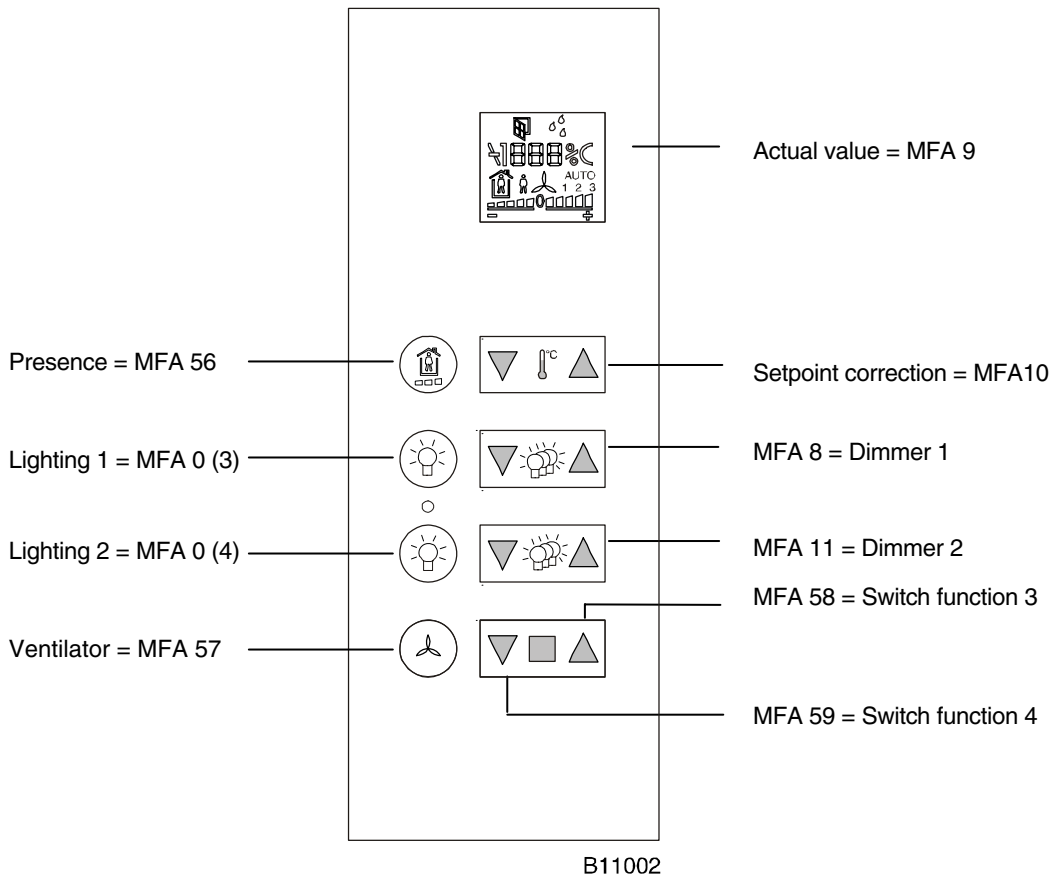

Engineering notes

The EYB 270 room operating unit is designed for recessed fitting in walls. The fixing bracket supplied with the unit enables it to be fitted onto a three-way recessed junction box (cf. accessories). The inscriptions or the function symbols can be adapted to the particular needs of the project (label inserts).

Linear correction is required for some data points (cf. the section entitled 'Linear correction').

Indication of actual value/setpoint in the display.

In the basic circuitry, the actual value (MFA 9) is shown in the display. If the user wants to view the setpoint (control parameter) of the *ecos*, this can be effected via a 0-10 V d.c. signal. This signal is fed to terminal X1/4. When this function is used, the direct display of the actual value in the EYB is no longer available.

If the user wants the actual value and setpoint to be displayed, this can be done by modifying the program in the *ecos*. The 0-10 V signal then equates to either the actual value or the setpoint.

The LCD range is then restricted: 0-10 V = 16°C – 25.5°C.

The keys for setpoint correction (MFA 10) must be used for this, since they are directly assigned to the bars in the LCD.

Linear correction is required for the capture of the actual value (cf. 'Linear correction').

Feedback on the LCD

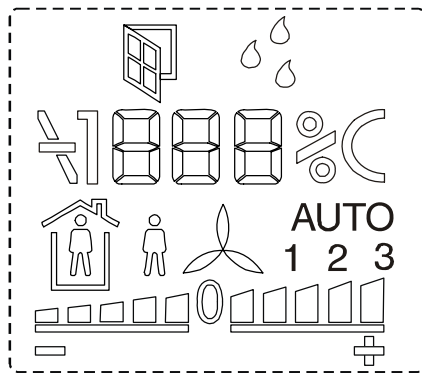

B10987

The room operating unit has an LCD with a multifunctional display.

- Indicator for 'window open'
- Indicator for 'dew point breached'
- Indicator for room temperature
- Indicator for operating mode (presence/absence)
- Indicator for ventilator mode manual/auto with speeds 0 - 1 - 2 - 3
- Indicator for setpoint correction +/- 5 steps; size of step can be parameterised

Feedback commands for ventilator and dew-point symbols

Apart from the two buttons for the setpoint correction, any other button can be used to switch the fan speeds. Ideally, this should be the button with **MFA 57**.

The indicator in the LCD must be activated via the *ecos* program.

Activation for both the fan-speed and the dew-point symbols is effected via **MFA 41**.

Commands 1, 2 and 3 control the fan-speed symbol, command 4 controls the dew-point symbol. A control logic program for the MFA 41 should be programmed accordingly in the *ecos*.

Bef. 1	Bef. 2	Bef. 3	Bef. 4	Anzeige	
				Bef. 1-3	Bef. 4
0	0	0	0	AUTO	
1	0	0	0	1	
0	1	0	0	2	
1	1	0	0	AUTO 1	
0	0	1	0	3	
1	0	1	0	AUTO 3	
0	1	1	0	AUTO 2	
1	1	1	1		

B10988a

Feedback commands for presence and window symbols





Apart from the two buttons for the setpoint correction, any other button can be used to switch the operating mode/presence. Ideally, this should be the button with **MFA 56**.

Here again, the indicator in the LCD must be activated via the *ecos* program.

Activation for both the presence and the window symbols is effected via **MFA 40**.

Command 1 controls the presence symbol, command 2 the window symbol.

A control logic program for MFA 40 should be programmed accordingly in the *ecos*.

Bef. 1	Bef. 2	Anzeige	
		Bef. 1	Bef. 2
0	0		
1	0		
1	1		

B10989a

Linear correction for various values with different *ecos* microprogram versions

Actual value of temperature Xi (MFA 9)

The indication of the actual value (Xi) is not a real feedback signal from the *ecos*, but is rather the measurement result in the room operating unit that is sent directly for displaying in the LCD.

The sensor is an NTC element with 10 kOhm at 25°C.

Because the sensor is an NTC element, the MFA 9 must be linearised in the *ecos* as follows:-

$$a = + 0.1175$$

$$b = + 4.8140$$

Setpoint correction dXs (MFA 10)

Linearisation is dependent on the desired correction value.

MFA 10 Linearisation correction factors Index <=G		
Range	a	b
+/- 1,0 °K	0,00348	-0,55
+/- 1,5 °K	0,005	-0,7
+/- 2,0 °K	0,00662	-0,952
+/- 2,5 °K	0,008333	-1,22
+/- 3,0 °K	0,0010043	-1,487
+/- 3,5 °K	0,011753	-1,754
+/- 4,0 °K	0,013463	-2,001
+/- 4,5 °K	0,015173	-2,248
+/- 5,0 °K	0,016883	-2,495

MFA 10 Linearisation correction factors Index >=H		
Range	a	b
+/- 1,0 °K	0,2	-0,1
+/- 1,5 °K	0,29	-0,16
+/- 2,0 °K	0,38	-0,24
+/- 2,5 °K	0,48	-0,29
+/- 3,0 °K	0,57	-0,34
+/- 3,5 °K	0,67	-0,4
+/- 4,0 °K	0,775	-0,4
+/- 4,5 °K	0,85	-0,505
+/- 5,0 °K	0,96	-0,53

N.B.: On leaving the comfort mode (presence = 0), the setpoint correction is automatically set to zero.

Dimming function for lighting (MFA 8 and 11)

Index <=G

No linearisation factors

Press button 'HIGH' = 490 units
 Press button 'LOW' = -209 units

The basic value without the button being pressed (idle condition) lies between 6 and 8 units.

Index >=H

Linearisation factors: a = 1.32,
 b = 0.4

Press button 'HIGH' = 1
 Press button 'LOW' = -1
 Idle condition = -0.379

Wiring diagram

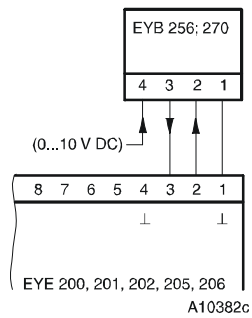

In cases where the industry standard (EN 61000-6-2) has to be met, the power cables should be no longer than 30 m.

Dimension drawing

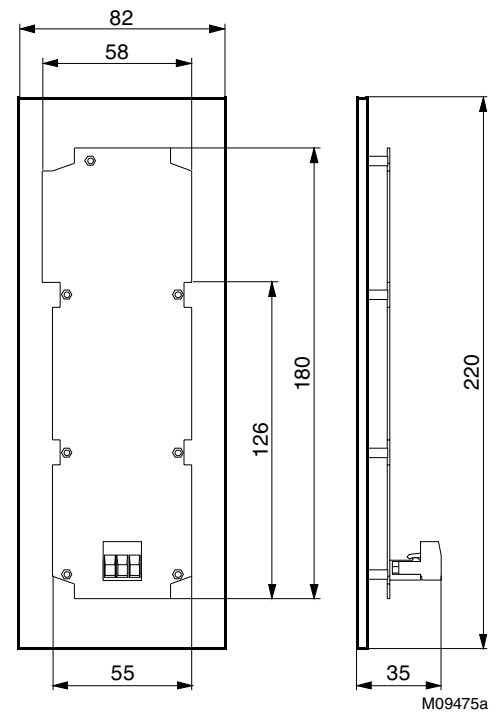

Junction box for recessed fitting

0382126 001

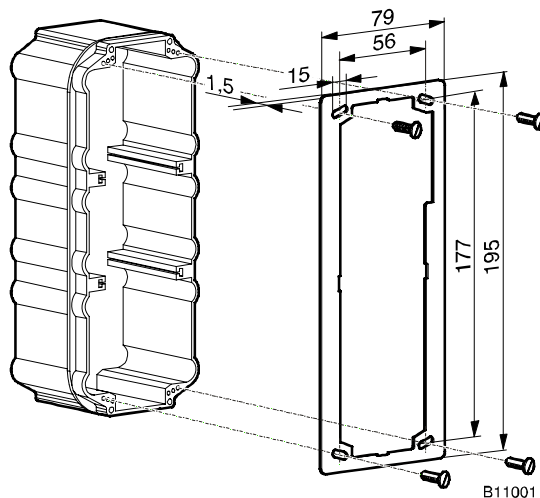

81 x 195 x 60 (W x H x D)