

**novaLink170:** Field module for AO 4 × 0...10 V or 2 × 0...10 V / 2 × 0...20 mA

The **novaLink170** field module enables four control signals of 0...10 V to be issued. Outputs 3 and 4 can also have the function 0...20 mA.

The unit is used as an 'intelligent terminal' and, therefore, reduces the time spent on wiring when fitted to a panel. Since it has optical indicator elements and manual input elements, the unit is employed as a local manual operating unit. To activate the unit, either the EYX 172 F001 driver card or the **nova225** or **nova215** automation station.

Application: for decentralised control of dampers, motors etc.

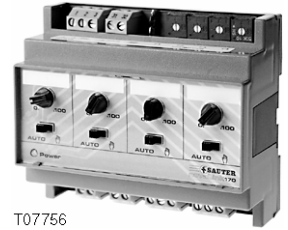

T07756

Type	Description	Weight [kg (lb)]
<b>EYY 170 F202</b>	Field module for AO 0...10 V or 0...20 mA, with LED and manual operation	0.24 (0.5)

**Technical details**

Activation driver card or automation station	EYX 172 F001	Permissible ambient temp Normal operation 0...45 °C (32...113°F) Transport and storage temp. -25...70 °C (-13...158°F)
<b>nova225</b> <b>nova215</b>	EYL 225 F001/F005 EYL 215 F001/F005	Ambient conditions: Humidity 10...90 %rh without condensation
Number of outputs	4 × 0...10 V or 2 × 0...10 V and 2 × 0...20 mA	Ambient class IEC 60721 3K3
<b>novaLink</b>	100 m max. (5 nF / 7.5 Ω) twisted and shielded, both ends to earth via <b>novaLink</b>	Wiring diagram <a href="#">A06441</a> Dimension drawing <a href="#">M07765</a> Fitting instructions <a href="#">MV 505393</a>
Power supply Back-up power supply	24 V~ or 24 V~ / UPS	Complies with:- EMC directive 89/336/EEC EN 61000-6-1/ EN 61000-6-2 EN 61000-6-3/ EN 61000-6-4
Max. current consumption Power loss, max.	100 mA approx. 0.1 W	Agency USA/Canada UL-listed: UL 916 CSA-certified: CSA C22.2

**Accessories**

<b>0367841 001</b>	Terminal cover	
<b>0374522 004</b>	Front insert, printable, comprising:- 25 sheets à 6 front inserts, perforated, for	EYY 170 F202
<b>0367958 001</b>	Set of front inserts, not printable, comprising:- 4 front inserts, single, for 25 front inserts, single, for 6 front inserts, single, for 10 front inserts, single, for 15 front inserts, single, for	EYY 160 F001 EYY 164 F202 EYY 165 F202 EYY 170 F202 EYY 174 F101
<b>0367961 001</b>	Set of adhesive labels comprising:- 1 sheet à 20 labels for 9 sheets à 80 labels for 2 sheets à 40 labels for 4 sheets à 100 labels for 11 sheets à 64 labels for	EYY 160 F001 EYY 164 F202 EYY 165 F202 EYY 170 F202 EYY 174 F101
<b>0374452 004</b>	Adhesive labels comprising:- 10 sheets à 100 labels for	EYY 170 F202

**Engineering notes**

The **novaLink170** field module can be fitted on a top-hat rail (EN 50022) in the panel or at a suitable place anywhere in the plant. The automation station is connected via the **novaLink**. The data and the power supply are transmitted via the **novaLink**. Each unit needs its own connection. When connecting, it is important to observe polarity. The distance to the driver card or automation station should not exceed 100 m. The novaLink must be twisted and shielded (both ends to earth).

The green LED ('Power') indicates that the connection is correct; it flashes in priority/watchdog mode or back-up power mode.

Change-over to back-up power is effected whenever the novaLink field telegram ceases to supply power. The back-up power, which comes either direct from a separate 24 V~ transformer (USA: power source class 2) or indirect from the UPS (EYZ 101 F001), is connected to terminals 31 and 32. Change-over to watchdog or priority mode is effected – depending on the bridge coding (bridge made = priority; bridge cut = watchdog) – whenever terminal 3 is at earth potential or the novaLink field telegram is malfunctioning.





In priority mode, the voltages pre-selected by the potentiometer are fed through to the output regardless of the position of the manual switch.

In watchdog mode, the voltages pre-selected by the potentiometer are fed through to the output only when the manual switch is in the 'Automatic' position. Manual control is still possible, however.

The 'Automatic' commands can be overridden by using the manual switches. If the switches are in the manual position, a value of 0...10 V can be set via the rotary potentiometer.

For outputs 3 or 4 respectively, the voltage of 0...10 V is tapped at terminals 8 and 9 or, alternatively, 10 and 11. By contrast, the current output of 0...20 mA is at terminals 8 and 19 or, alternatively, 10 and 21.

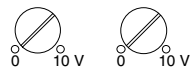
**Table of functions**

Priority/ watchdog   3	 Auto	 Auto Manual
	Command from AS	F1 ... F4 
Priority/ watchdog   3	F1 F2 F3 F4 	

B04682a

**Wiring diagram**

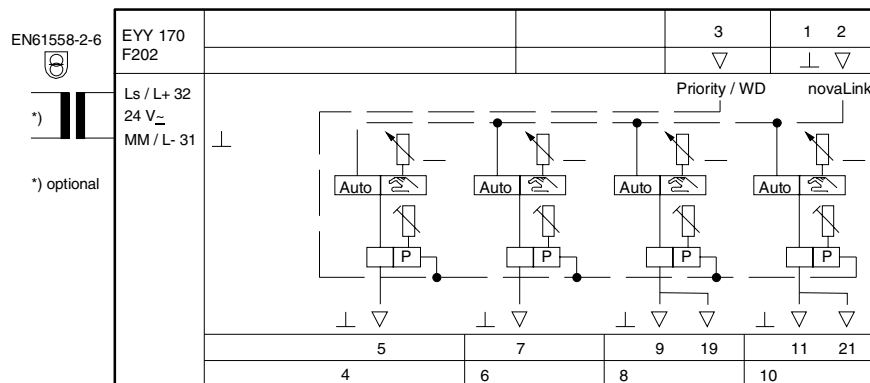

\* USA: power source class 2

A06441c

Dimension drawing

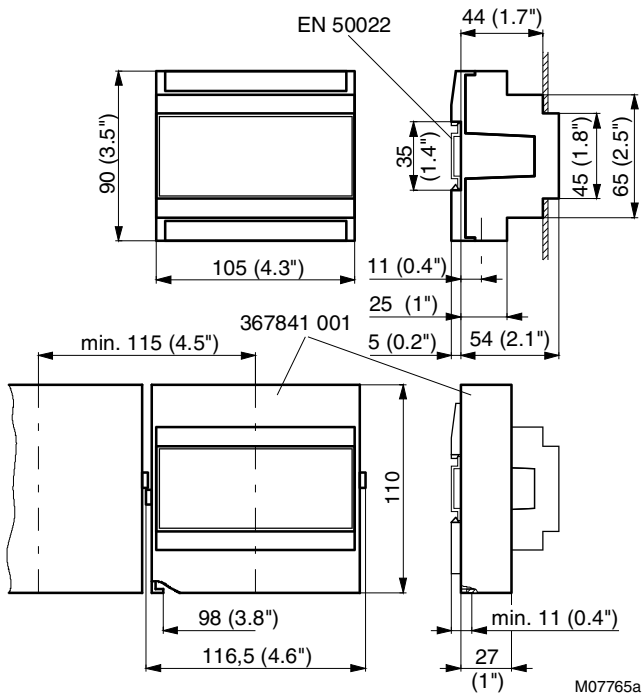

Example of connection

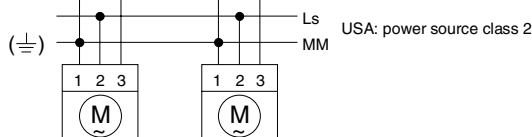
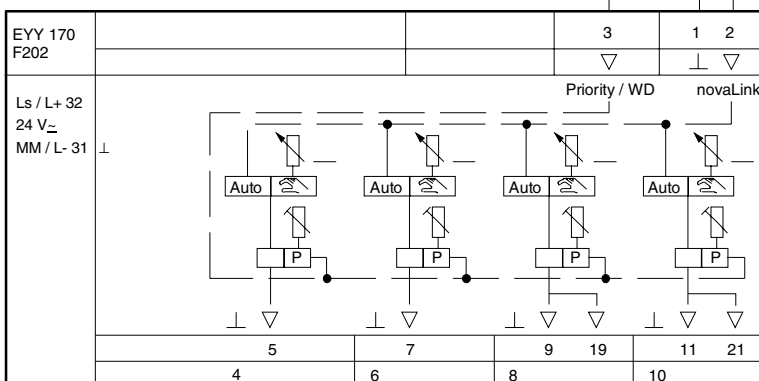
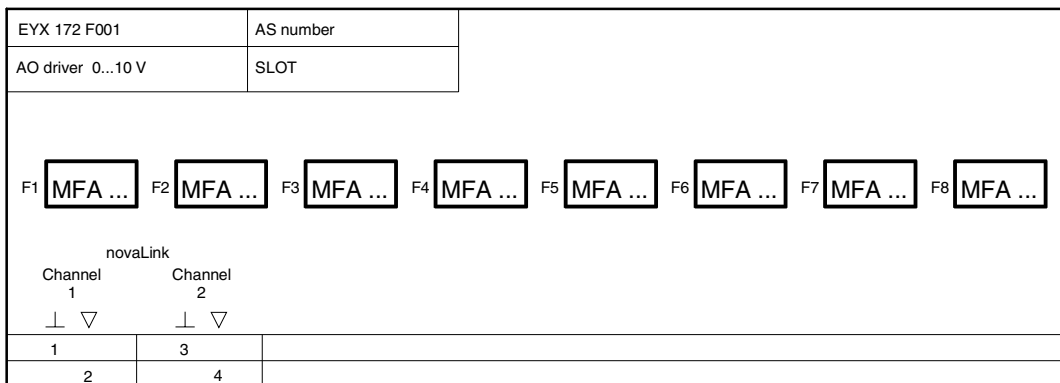

In cases where the industry standard (EN 61000-6-2) has to be met, the power cables and the **novaLink** power cable should be no longer than 30 m.

