

novaLink164: Field module for 0-I commands

The **novaLink164** field module allows four 0-I switching commands to be issued. Being an 'intelligent terminal', it greatly reduces the time spent on wiring. Since it has optical indicator elements and manual input elements, the unit can be employed as a local manual operating unit. To activate the unit, either the EYX 168 F001 driver card or the **nova225** or **nova215** automation station is used.



Type	Description	Weight [kg (lb)]
EYY 164 F202	Field module (0-I command) with LED and manual operation	0.24 (0.5)
Technical details		
Activation driver card or automation station nova225 nova215	EYX 168 F001 EYL 225 F001/F005 EYL 215 F001/F005	Permissible ambient temp. 0...45 °C (32...113°F) Transport & storage temp. -25...70 °C (-13...158°F) Permissible humidity 10...90 %rh without condensation IEC 60721 3K3
Number of outputs	4 × 0-I	Wiring diagram A06036
Switching voltage	250 V~ (CE-comform) 30 V~ (UL-listed)	Dimension drawing M07765
novaLink	100 m max. (5 nF / 7.5 Ω) twisted and shielded, both ends to earth	Fitting instructions MV 505392
Power supply	via novaLink	Complies with:- EMC directive 89/336/EEC
Back-up power supply	24 V~ or 24 V~ / UPS	EN 61000-6-1/ EN 61000-6-2 EN 61000-6-3/ EN 61000-6-4
Max. current consumption	150 mA	Agency USA/Canada
Power loss, max.	approx. 2 W	UL-listed: UL 916 CSA-certified: CSA C22.2

Accessories

0367841 001	Terminal cover	
0374522 002	Front insert, printable, comprising:- 25 sheets à 6 front inserts, perforated, for	EYY 164 F202
0367958 001	Set of front inserts, not printable, comprising:- 4 front inserts, single, for 25 front inserts, single, for 6 front inserts, single, for 10 front inserts, single, for 15 front inserts, single, for	EYY 160 F001 EYY 164 F202 EYY 165 F202 EYY 170 F202 EYY 174 F101
0367961 001	Set of adhesive labels comprising:- 1 sheet à 20 labels for 9 sheets à 80 labels for 2 sheets à 40 labels for 4 sheets à 100 labels for 11 sheets à 64 labels for	EYY 160 F001 EYY 164 F202 EYY 165 F202 EYY 170 F202 EYY 174 F101
0374452 002	Adhesive labels comprising:- 10 sheets à 80 labels for	EYY 164 F202

Engineering notes

The **novaLink164** field module can be fitted on a top-hat rail (EN 50022) in the panel or at a suitable place anywhere in the plant. The automation station is connected via the **novaLink**. The data and the power supply are transmitted via **novaLink**. Each unit needs its own connection. When connecting, it is important to observe polarity. The distance to the driver card or automation station should not exceed 100 m.

The **novaLink** must be twisted and shielded (both sides to earth). The green LED ('Power') indicates that the connection is correct; it flashes in priority/watchdog mode or back-up power mode.

Change-over to back-up power mode is effected whenever the novaLink field telegram ceases to supply power. The back-up power, which comes either direct from a separate 24 V~ transformer (USA: power source class 2) or indirect from the UPS (EYZ 101 F001), is connected to terminals 31 and 32.

Change-over to watchdog or priority mode is effected – depending on the bridge coding (bridge made = priority; bridge cut = watchdog) – whenever terminal 3 is at earth potential or the novaLink field telegram is malfunctioning.



In priority mode, the switching stages pre-selected by the DIP switches are fed through regardless of the position of the manual switch.

In watchdog mode, the switching stages pre-selected by the DIP switches are fed through only when the manual switch is in the 'Automatic' position. Manual control is still possible, however.

An optical indicator for exclusively simulated feedback signals is located on the field module. The green LEDs indicate the relevant switching stage.

The 'Automatic' commands can be overridden by using the manual switches.

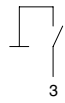
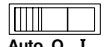
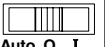
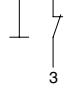
Table of functions

Priority 	Auto  Auto O I	Manual  Auto O I					
	Command from AS O	I					
Priority 	F1 F2 F3 F4 	<table border="1"> <tr> <td>ON</td> <td>I</td> </tr> <tr> <td>Off</td> <td>0</td> </tr> </table>	ON	I	Off	0	
ON	I						
Off	0						

B04637

Pre-selection of priority levels

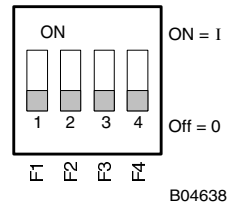

Wiring diagram

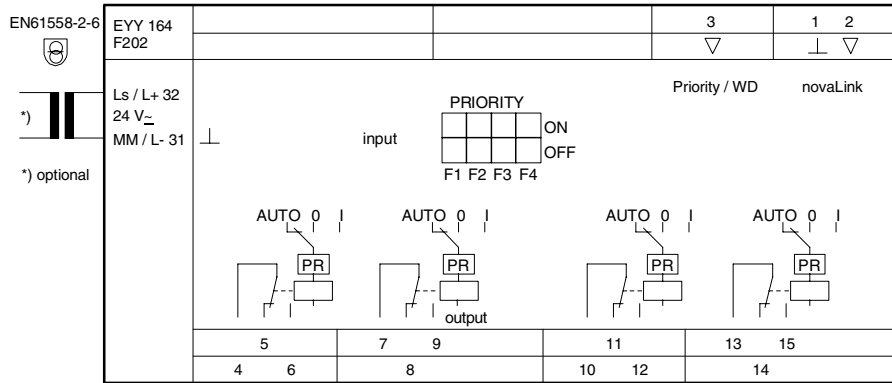

* USA: power source class 2

250 V~ 2(2) A (CE-Conform)
30 V~ 2(2) A (UL-Listed)

A06036e

Dimension drawing

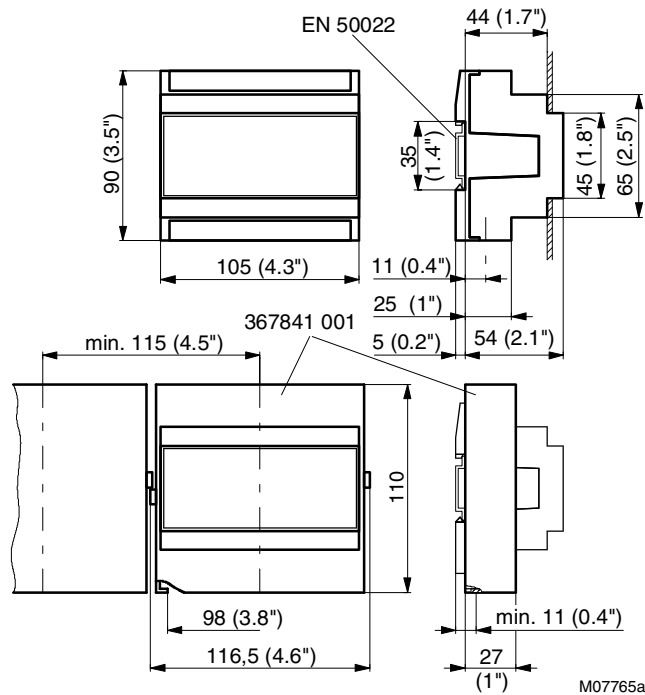

Example of connection

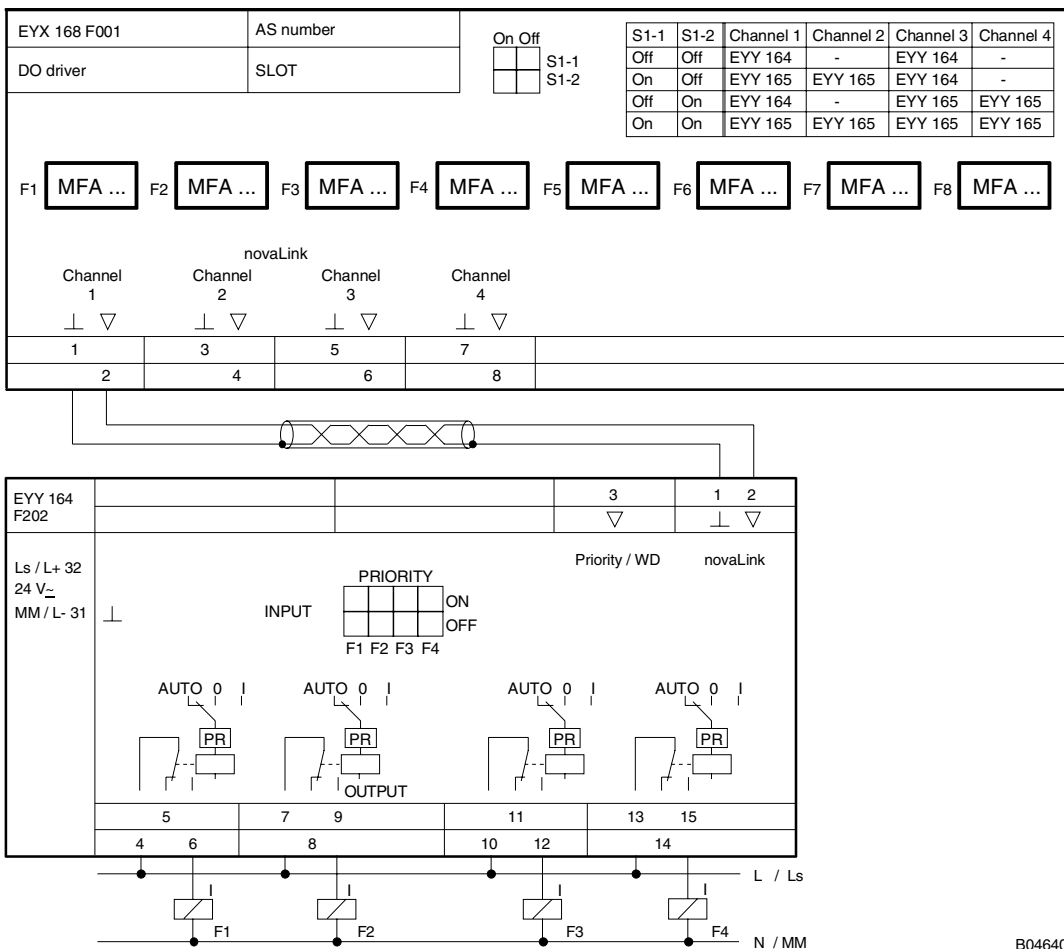

B04640d

In cases where the industry standard (EN 61000-6-2) has to be met, the **novaLink** power cable should be no longer than 30 m.

