

RCP 40: Damper control unit

For use in ventilation and air-conditioning systems for the control and minimum-limitation of the outside-air/re-circulated-air damper position for summer and winter operation.

Housing and insert of thermoplastic; front door of thermoplastic; front plate with the setting knobs and three covered openings for plug-in manometers (XMP); all settings can be made using a coin and the % scale; measuring connection M4; control action A and B (trapezium diagram); suitable for wall or panel mounting; compressed-air connection Rp 1/8 female thread; includes a bag of scales (297103).

Type	Description	Air capacity	Air consumption ¹⁾	Weight [kg]
RCP 40 F001	trapezium diagram	400 l _r /h	70 l _r /h	0.7
Supply pressure ²⁾	1.3 bar ± 0.1	Permissible amb. temp.		0...55 °C
Input pressures	0.2...1.0 bar	Connection diagram		A02692
Output pressures	0.2...1.0 bar	Dimension drawing		M297100
Shift starting pt. KP ₃ , KP ₅	0...100%	Fitting instructions		MV 3247
P-band X _{P3} , X _{P5}	0...100%			
Minimum limiter B	0...100%			

Accessories

0297103 000 Additional bag of scales with 8 different scales according to the transducer used.

0297133 000 Universal scales for setpoint adjuster X_S; gradation 120, 80/160, 50/100, 30/60

- Without transducer; air consumption for transducer connections 3 and 5 is 33 l_r/h more in each case.
- See Section 60 on regulations concerning the quality of supply air, especially at low ambient temperatures.

Operation

The pressure at connections 3 and 5 is fed in each case to an amplifier with variable shift starting point KP (zero point) and variable P-band X_P (amplification). The amplifier at input 3 has control action A; the one at input 5 has control action B. Due to the following minimum selection, the smaller of the two amplifier outputs is always passed on. This forms a trapezoidal characteristic which can be rotated at the KP points (at 0 bar). Both characteristics are limited to a (variable) minimum value by the following limiter B.

In its main use, a transducer is fed to both inputs, e.g. for the control of a fresh-air damper dependent on outside temperature (trapezium diagram).

The fresh-air damper can also be controlled with dependency on two separate transducers, e.g. damper control dependent on outside temperature in summer, and control of the mixed-air temperature in winter.

A restrictor (Ø 0.2 mm) for supplying the transducer is fitted at connection 3. If a second transducer is connected to connection 5, then a separate restrictor (Ø 0.2 mm) is needed. The signals from the transducer (connections 3 and 5) and the output pressure can be checked via the M4 measuring connection or indicated via the manometer.

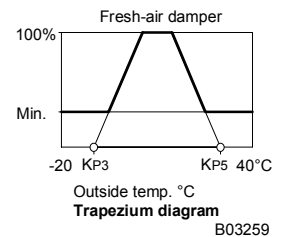
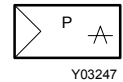

Additional details

Front plate with adjusters for P-bands (X_{P3} , X_{P5}), shift starting point (KP3, KP5) and limitation (B).

Additional information on accessories

0297103 000 Additional bag of eight alternative scales
 5...35 °C 20...90 %rh
 -20...40 °C 0...5 mbar
 0...120 °C 5...10 mbar
 80...200 °C 10...15 mbar

Technical information

Technical manual: *centair* system 304991 003

Connection diagrams

Damper control for summer and winter

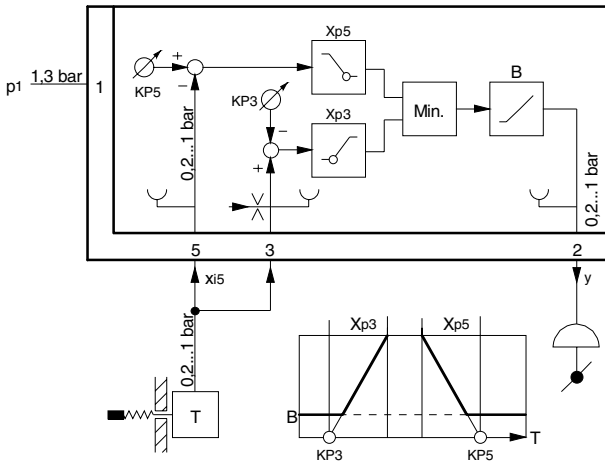

Open-loop control in summer, closed-loop control in winter

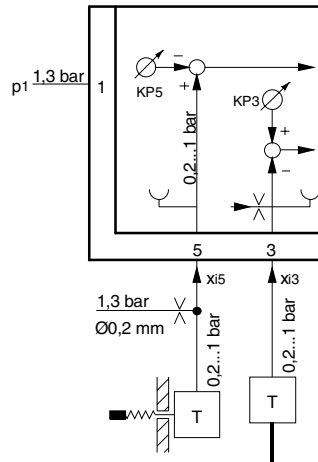

A02692

1	Supply pressure	KP3	Shift starting point, summer	B	Minimum limiter
2	Output pressure	KP5	Shift starting point, winter	x_{i3}	Mixed-air temperature
3	Input for control action A (winter)	X_{P3}	P-band, summer	x_{i5}	Outside temperature
5	Input for control action B (summer)	X_{P5}	P-band, winter	y	Output pressure

Dimension drawing

