

AVM 124S, 125S: Valve drive with Sauter Universal Technology SUT

For controllers with continuous output (0...10V) or switched output (2-point or 3-point control). To operate through valves or three-way valves in series VXN/BXN, VUD/BUD, VUE/BUE. Characteristic (linear/equal-percentage/quadratic) can be set at the positioner.

Housing of fire-retardant plastic, with stepping motor, electronic control unit, LED indicator and gears; body of gears and fixing bracket (for fitting the valve) are of cast zinc. Transparent lid of fire-retardant plastic. Electronic force-dependent cut-out by means of stops either in the drive or on the valve; automatically adapted to the valve stroke; coding switch for changing the characteristic and running time; external manual adjustment with power cut-off. Direction of operation can be changed over externally (power supply to terminal 2a or 2b, 01 or 02 respectively); electrical connection (max. 1.5 mm²) by screw terminals; cable inlet M20x1.5; can be fitted in any position between vertical (upright) and horizontal.



T09865



Y07552

Type	Running time [s]	Stroke ⁵⁾ [mm]	Pushing force [N]	Power	Weight [kg]
For valves with linear characteristic, can be switched over to equal-percentage					
AVM 124S F132	30 / 60 / 120	7.5	800	24 V~	2.1
For valves with equal-percentage characteristic, can be switched over to linear					
AVM 125S F132	30 / 60 / 120	8.0	800	24 V~	2.1

Positioner: ¹⁾

Control signal 1	0...10 V, R _i > 100 kΩ	Starting point U ₀	0 or 10 V
Control signal 2	4...20 mA, R _i = 50 Ω	Control span ΔU	10 V
Position feedback signal	0...10 V, load > 2.5 kΩ	Switching range X _{Sh}	200 mV

Power supply	24 V~ 24 V = ²⁾	± 20%, 50...60 Hz + 20% / - 10%	Degree of protection ³⁾ Protection class	IP 54 as per EN 60529 III as per IEC 60730
Power consumption	5 W	8.4 VA	Wiring diagram	AVM 124 A09856 AVM 125 A10451
Max. media temperature	100 °C		Dimension drawing	M07430
Permissible ambient temp.	-10...55 °C		Fitting instructions	AVM 124 MV 505809 AVM 125 MV 506066
Ambient humidity	< 95 %rh without condensation		Fitting instructions	AVM 125 MV 506066
			Declaration on materials	MD 51.366

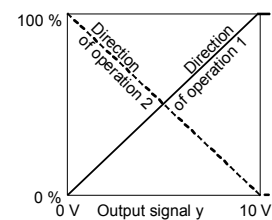

B07650

Accessories

- 0313529 001*** Split-range unit for settings sequences. [MV 505671](#); A09421
- 0370880 001** Mechanical stroke indicator; [MV 505517](#)
- 0370881 001*** Auxiliary change-over contacts ⁴⁾, single; [MV 505517](#)
- 0370882 001*** Auxiliary change-over contacts ⁴⁾, single, and pot.2000 Ω, 1 W; 24 V; [MV 505517](#)
- 0370882 006*** Auxiliary change-over contacts ⁴⁾, single, and pot.1000 Ω, 1 W; 24 V; [MV 505517](#)
- 0370883 001*** Potentiometer 2000 Ω, 1 W; 24 V; [MV 505517](#)
- 0370883 006*** Potentiometer 1000 Ω, 1 W; 24 V; [MV 505517](#)
- 0372249 001*** Intermediate piece required for media temperature >100 °C for BXN / VXN (recommended for temperature < 10 °C); [MV 505932](#)
- 0372460 001** Cable screw fitting (plastic M20x1.5) incl. locking nut and gasket, max. 2 pcs.

¹⁾ Dimension drawing or wiring diagram are available under the same number

- 1) Also for 2-point or 3-point, depending on connection
- 2) 24V= only for 0...10V input signal
- 3) Degree of protection IP 54 only with M20 cable screw fitting
- 4) Infinitely variable; max. load 2 (1) A, 12...250 V~, min. load 250 mA, 12 V~
- 5) Maximum stroke of drive = 10.0 mm

Operation

Depending on how it is connected (see wiring diagram), the actuator can be used as a continuous drive (0...10V and/or 4...20 mA), a 2-point drive (open/close) or a 3-point drive (open/stop/close) with intermediate position. When control signals 1 (3u, 03 respectively) and 2 (3i, 04 respectively) are connected simultaneously, the input with the highest value has priority.

The running time can be matched to requirements using switches S1 and S2. The characteristic (equal-percentage, linear or quadratic) can be selected with switches S3 and S4. The AVM 124S is combined with valves that have a linear basic characteristic such as the VXN and BXN valves. The AVM 125S is combined with valves that have an equal-percentage basic characteristic such as the VUD, BUD, VUE and BUE valves. The AVM 125S can be fitted on a valve with a linear characteristic (e.g. VUE 050F200), but you must pay attention to the position of the coding switches.

Manual adjustment is done using the external handle. When this handle is pulled out, the motor cuts out. When the handle is put back in again, the drive again moves to the closed position and re-adjusts itself (continuous mode).

Connected as a 2-point actuator

Opening/closing can be effected via two wires. Power is applied to the drive via terminals 1 and 2b. On connecting power to terminal 2a, the valve's control passage closes. When power is switched off, the drive goes to the opposite end position and opens the valve.

Connected as a 3-point control unit

By connecting power to terminal 2a / 01 or 2b / 02, the valve can be moved to any position. The coupling rod extends and opens the valve if power is applied to terminals 1 / MM and 2b / 02. It retracts and closes the valve if the power circuit is closed via terminals 1 / MM and 2a / 01.

In the end positions (on hitting a stop in the valve or reaching the maximum stroke) or in the event of an overload, the electronic motor cut-off responds (no end switches). The direction of the stroke can be changed by swapping the power-supply wires over (2a, 2b / 01, 02).

Connections for control voltage 0...10V and/or 4...20 mA

The integrated positioner controls the drive as a function of the controller's positioning signal y.

The voltage signal of 0...10 V- is connected to terminal 3u / 03 and the current signal is connected to terminal 3i / 04.

Direction of operation 1 (mains power at internal connection 2a / 01): the coupling rod extends and opens the valve (control passage) as the positioning signal rises.

Direction of operation 2 (mains power at internal connection 2b / 02): the coupling rod retracts and closes the valve (control passage) as the positioning signal rises.

The starting point and the control span are both pre-set.

There is a split-range unit available (as an accessory) for setting partial ranges (only for control signal 1). After manual adjustments have been made, or when there is a power failure lasting longer than 5 minutes, the drive re-adjusts itself automatically (always with a running time of 60 seconds).

After power has been applied, the stepping motor moves to the lower stop, connects to the valve spindle, moves to the upper stop in the valve, thereby determining the closed position. Depending on the control voltage, any stroke between 0 and 8 mm can then be obtained. Thanks to the electronics unit, no steps are lost, and the drive needs no periodical re-adjustment. Parallel operation of more than one drive of the same type is guaranteed.

The feedback signal y0 = 0...10V corresponds to the effective stroke of 0 to 8 mm.

The valve's characteristic can be selected using the coding switch. The characteristics can be generated only if the drive is used as a continuous drive. Other switches enable the running times to be set. These can be applied irrespective of whether the 2-point, 3-point or the continuous function has been chosen.

Coding switch for running time selection

AVM 124S, AVM 125S

Run time per mm	Switch coding	Run time for 8 mm stroke
3,75 s		30 s ± 1
7,5 s		60 s ± 2
15 s		120 s ± 4
= factory setting		

B10706

Coding switch for characteristics selection

AVM 124S

Desired character. curve	Switch coding	Characteristic curve for valve	Characteristic curve for drive	Effective on valve
Linear				
Equal percentage				
Linear				
Quadratic				
Linear				
= factory setting				

B10707a

Coding switch for characteristics selection

AVM 125S

Desired character. curve	Switch coding	Characteristic curve for valve	Characteristic curve for drive	Effective on valve
Equal percentage				
Quadratic				
Linear				
Equal percentage				
Linear				
= factory setting				

B10708

LED indicator

green

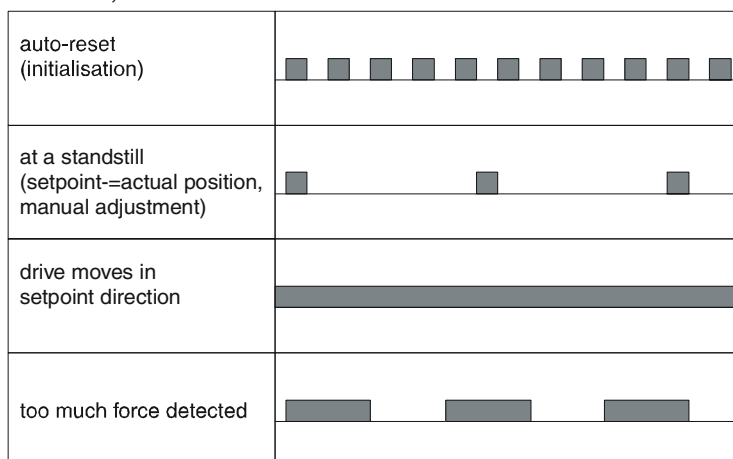
AVM 124S, AVM 125S

B09864a

Split-range unit, accessory 0361529 001

The starting point U_0 and the control span ΔU can be set using the potentiometer. This makes it possible to activate several regulating units in sequence or in cascade using the controller's control signal. The input signal (partial range) is amplified into an output signal of 0...10V. This accessory can be fitted in the drive, or can be fitted externally in an electric distribution box.

If the control signal (0...10V) is interrupted and direction of operation 1 is set, the valve closes fully (position 0%).

Engineering and fitting notes

The ingress of condensate, drops of water etc. along the valve spindle and into the drive should be prevented.

With the electrical connection, you must also make sure that the cross-section of the supply line is adapted to the power and length. In any case, however, we recommend that the cross-section should not be less than a minimum of 0.75 mm². The drive and valve are assembled by fitting together and tightening the cap nut without further adjustment. The drive is supplied ex works in the middle position. The combination of stepping motor and electronics allows several actuators of the same type to be run in parallel.

The maximum number of accessories that can be fitted is one stroke indicator plus one additional accessory: auxiliary contacts, potentiometer or combination, or split-range unit.

Fitting outdoors. If the devices are fitted outdoors, we recommend that additional measures be taken to protect them against the effects of the weather.

Additional technical information

Transparent cover with lever for manual adjustment. The black housing holds the stepping motor and the electronic control unit. Underneath is the maintenance-free gear unit. By breaking out a pre-scored circle in the housing, it is possible to create an aperture to fit a second M20 cable screw fitting.

Auxiliary change-over contacts

Switch rating: max. 230V a.c.; min. current 20 mA at 20V

Switch rating: 4...30V d.c.; current 1...100 mA

Power consumption:

Type	Running time s	Condition	active power P	apparent power S
			W	VA
AVM 124S F132	30	Operating	3.3	4.8
		Standstill	1.75	2.8

CE conformity

EMC directive 89/336/EEC

Machine directive 98/37/EEC//B

EN 61000-6-1

EN 1050

EN 61000-6-2

EN 61000-6-3

EN 61000-6-4

Wiring diagram

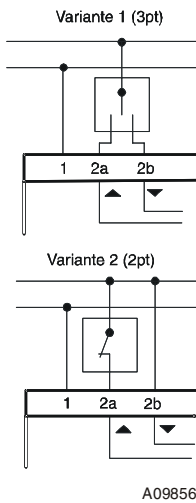
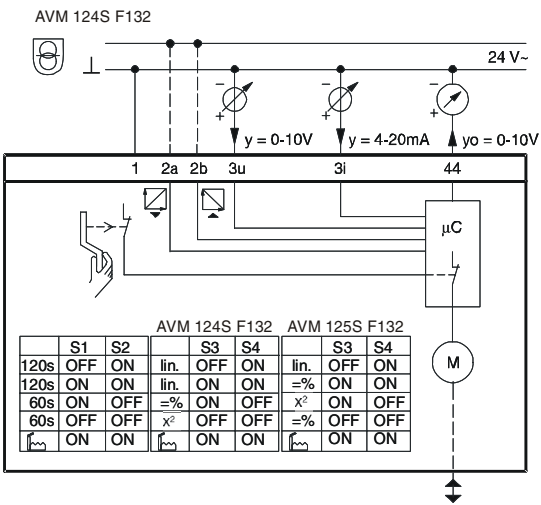

Accessories

370881

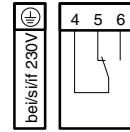

A01360a

370882

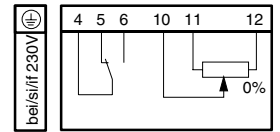

A06226a

370883

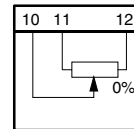

A01363

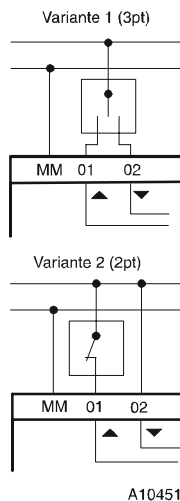
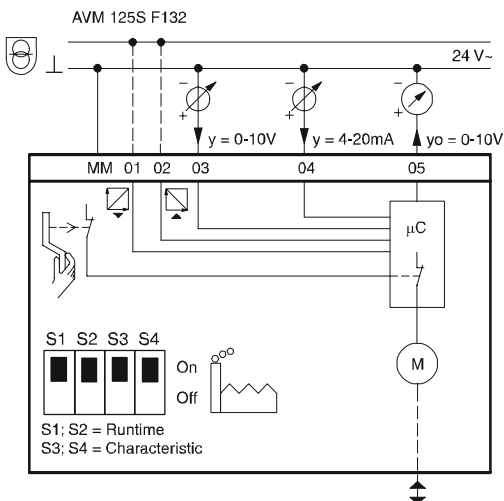

0313529

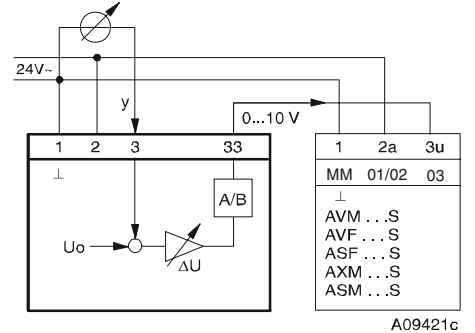

Dimension drawing

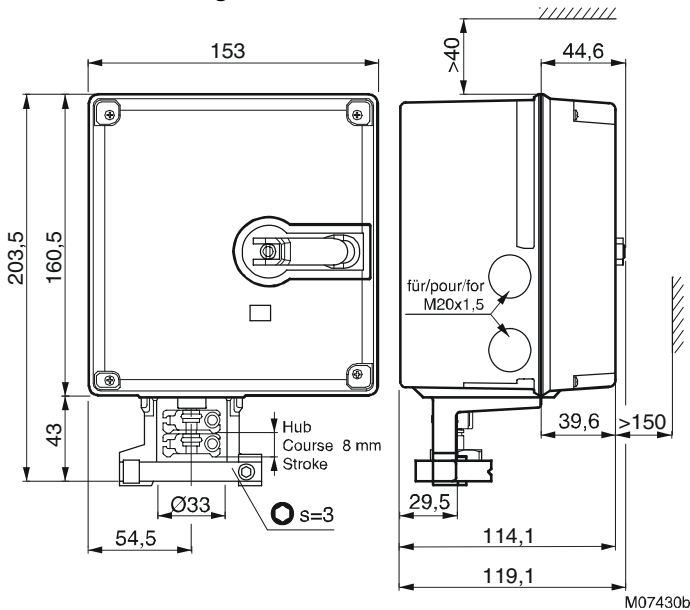

0372249 001

