

A44 W . S: Motor drive with positioner

For controllers with a continuous output (0...10 V or 0...20 mA). For operating final control elements such as air dampers, silde valves, butterfly valves etc.

Housing of light alloy, holding the reversible motor, the gearbox and the positioner. Cover of self-extinguishing thermoplastic. Lever for manual adjustment with automatic motor shut-off. Positioner with reversible direction of operation. Priority switching (open/stop/close) possible. Electrical connections (max. 1.5 mm²) via screwed terminals; cable screw fitting M20x1.5 with grommet.



T04258



Y07552

Type	Torque [Nm]	Holding torque [Nm]	Running for 90° [s]	Voltage	Weight [kg]
A44 W0S F001	25	22	30	24 V~	2.7
A44 W1S F001	30	30	60	24 V~	2.7
A44 W2S F001	30	30	120	24 V~	2.4

Positioner:

Control signal 0...10 V	$R_i = 30 \text{ k}\Omega$	Setting range	
0...20 mA	$R_i = 50 \Omega$	Starting point U_o	0.4...9.1 V
Positional feedback 0...10 V	max. load $\geq 2.5 \text{ k}\Omega$	Control range ΔU	1...10 V
0...620 mV	max. load $\geq 100 \text{ k}\Omega$	Switching range X_{Sh}	4% of ΔU
Supply voltage 24 V~	$\pm 20\%$, 50...60 Hz	Angle of rotation ²⁾	90°
Power consumption at 50 Hz		Perm. ambient temperature.	-5...50 °C
A44 W0S, A44 W1S	12.2 W	Perm. ambient humidity	< 95 %rh
A44 W2S	6.8 W	Degree of protection ³⁾	IP 43 (EN 60529)
Standstill	3 VA	Wiring diagram	A01345
Perm. damper area ¹⁾		Dimension drawing	M370550
A44 W0S	8 m ²	Fitting instructions	MV 505006
A44 W1S, A44 W2S	10 m ²		

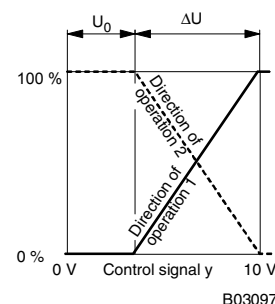

B03097

Accessories

- 0188614 000*** Fixing bracket for wall mounting
- 0274605 000*** Angle ball joint for clamp-on lever, with M10 nut
- 0294967 000*** Pivot-pin for clamp-on lever
- 0370479 000*** Bright galvanised steel cover with lever for external manual adjustment, rubber seal, degree of protection IP 55, olive. Fitted as per [MV 505005](#)
- 0370486 000*** Clamp-on lever, complete (incl. square-head hub)
- 0370493 000*** 2 plug-in auxiliary change-over contacts ⁴⁾, 10 (2) A 250 V~, [MV 505004](#)
- 0370628 000*** Adaptor plate including four M6 counter-sunk screws for replacing A33 W by A44 W.
- 0370638 000*** Straight ball joint for clamp-on lever, with M10 nut
- 0370715 001*** Cover of diecast aluminium, with rubber seal, degree of protection IP 55
- 0371290 001*** Black cover of diecast aluminium; with window, rubber seal, position indicator and scale. Fitted as per [MV 505329](#), degree of protection IP 55
- 0372460 001** Cable screw fitting (plastic M20x1.5) incl. locking nut and gasket, max. 3 pcs.

^{*)} Dimension drawing or wiring diagram are available under the same number

- 1) The recommended permissible damper area applies to equal-sided, easy-action dampers.
- 2) Angle of rotation of end shaft is 90° (factory set). Changing the arrangement to 180° is possible by reversing the cogs and readjusting the limit switches. Refer to fitting instruction [MV 505228](#).
- 3) Degree of protection IP 43 is attained only in conjunction with cable screw fitting M20x1.5. Degree of protection IP 55 is attained with steel or aluminium cover (accessory) and cable screw fitting M20x1.5.
- 4) Switching cam 180° ON or 180° OFF can be positioned at any point over the entire angle of rotation (360°).

Operation

The built-in positioner controls the positioning motor depending on the controller output signal y. The direction of operation 1/2 can be selected with switch S2. Direction of operation 2 (delivery setting): the end shaft rotates counterclockwise (seen from the drive unit towards the regulating unit). Starting point is U_0 and control range ΔU can be set. The reversible synchronous motor is switched off by limit switches at its end positions; self-locking is in this case insured by a built-in magnetic brake. Using the hand crank for manual operation will interrupt the neutral conductor of the motor by means of a switch. Priority circuit; the regulating unit can be driven to any intermediate position by making the electric circuit at terminals 1-5 or 1-6 respectively. Viewed from the drive towards the valve, the output shaft rotates in an anti-clockwise direction if the voltage is present at terminal 6.

Engineering and fitting notes

The output signal Y_0 (stroke 0...100 %) can be altered from 0...620 mV to 0...10 V by changing a plug connection. The rotation angle of 90° can be changed to 180° by reversing both gear wheels and readjusting the limit switches. Limit and auxiliary change-over contacts are set centrally at the switch dome which is mechanically connected directly to the end shaft (installation instruction [MV 505228](#)). The max. internal equipment of the drive unit comprises: 2 change-over limit switches (standard) and 2 auxiliary change-over contacts. The connection terminals for auxiliary functions are located at the corresponding limit and auxiliary switches or on the potentiometer, resp. (max.1.5 mm²); the protective conductor terminal is located on the steel coverplate. The drive unit is fastened through four M6 holes on the end shaft side. The motor drive can be installed in any position.

Fitting outdoors. If the devices are fitted outdoors, we recommend that additional measures be taken to protect them against the effects of the weather.

Additional technical data

Storage and transportation temp. limits	-30...70 °C	Complies with:-	
Power consumption at 60 Hz		EMC directive 89/336/EEC	EN 61000-6-1/ EN 61000-6-3
A44 W0S, A44 W1S	13.4 W		EN 61000-6-4
A44 W2S	7.8 W		
Standstill	3 VA		

Additional accessory data

- 0370493 000** (2 auxiliary contacts) min load: 100 mA, 24 V~
- 0370479 000** (steel cover w/ manual adjustment) olive, hammer enamel finish RAL 1020

Wiring diagram

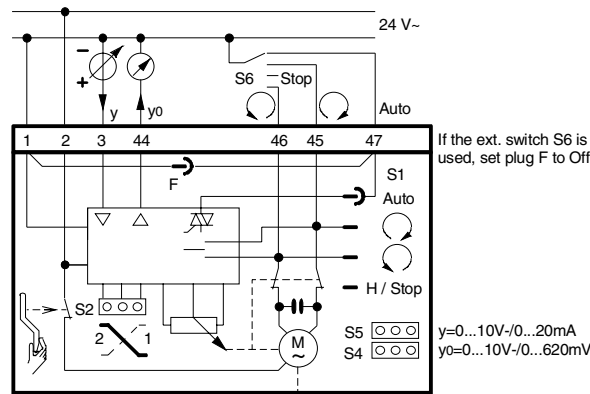

Anti-clockwise direction when direction of operation is 2 and y is rising (viewed from the drive towards the final control element)

A01345a

Accessories

370493

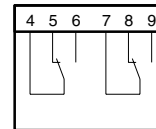

A01361

Dimension drawing

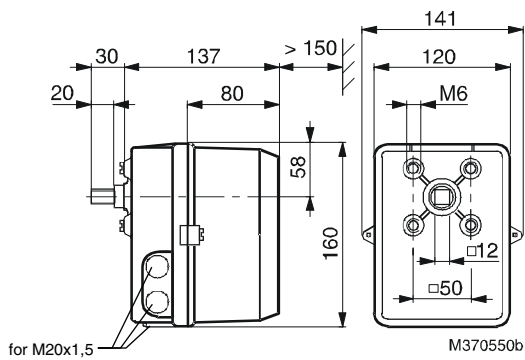

Accessories

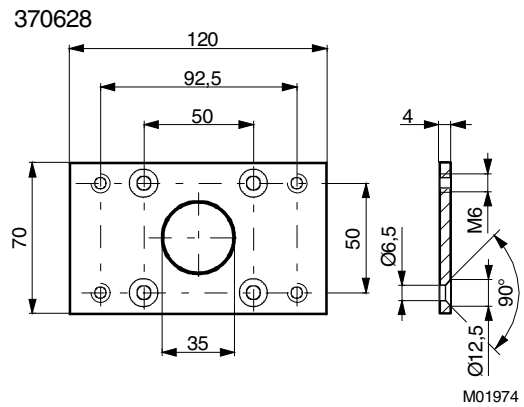

370715
371290

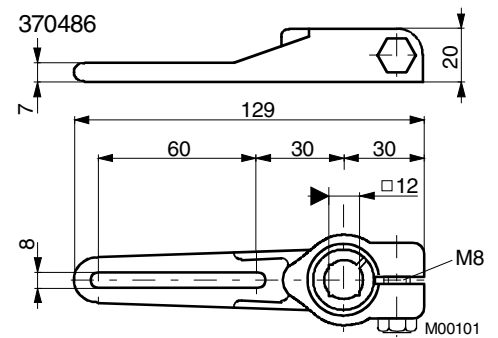
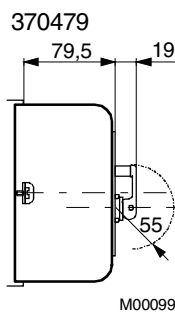
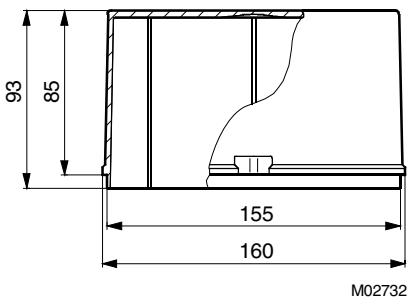

274605

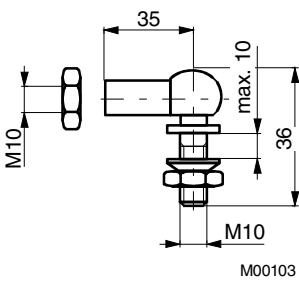

188614

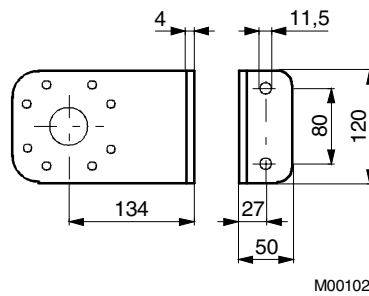

294967

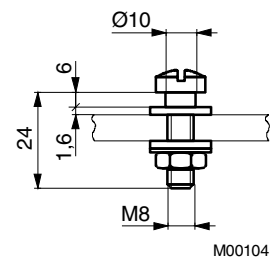

370638

