

ASM 124S, 134S: Actuators with Sauter Universal Technology (SUT)

For controllers with continuous output (0...10 V) or switched output (two- or three-point control). For the operation of air dampers, cut-off dampers and multi-louvre dampers.

Two-piece housing of fire-retardant plastic, black lower part, yellow upper part. With stepping motor, SUT electronic control unit and maintenance-free gearbox. Self-centring spindle adaptor for fitting to the damper spindle. Direction of operation can be changed at the cable. Electronic, torque-based cut-out via stops on either the actuator or the air damper. Coding switch for choosing the running time and initialising function. Gearbox can be de-coupled in order to position the damper or to make manual adjustments. Power cable is 1.2 metre long, $5 \times 0.75 \text{ mm}^2$, fixed to the housing. Fixing bracket, which functions as an anti-torsion device, has two metal screws. Suitable for fitting in any position. M5 thread holes for fitting to fixing bracket.



T09656



Y07552

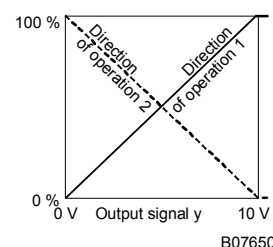

B07650

Type ⁵⁾	Torque [Nm]	Holding torque [Nm]	Running time for 90° [s]	Power	Weight [kg]
ASM 124S F132	15	15	60, 120	24 V~	1.2
ASM 134S F132	30	30	120, 240	24 V~	1.2

Positioner ¹⁾		Starting point U ₀	0 or 10 V
Control signal	0...10 V, R _i > 100 kΩ	Control span ΔU	10 V
Positional feedback signal	0...10 V, load > 10 kΩ	Switching range X _{Sh}	200 mV

Power supply	24 V ± 20%, 50...60 Hz 24 V = ²⁾ ± 20%	Permissible ambient temp.	-20...55 °C
Power consumption		Permissible ambient humidity	< 95 %rh without condensation
ASM 124S F132	2.4 W 4.4 VA	Degree of protection	IP 54 as per EN 60529
ASM 134S F132	2.4 W 4.3 VA	Protection class	III as per IEC 60730
Angle of rotation	90° ³⁾	Running noise	< 30 dB(A)
Damper spindle		Response time	200 ms
ASM 124S F132	∅ 10...20 mm □ 10...16 mm	Connection diagram	A09681
ASM 134S F132	∅ 12...20 mm □ 10...16 mm	Dimension drawing	M05671
Damper spindle (hardness)	max. 300 HV	Fitting instructions	
		ASM 124S F132	MV 505792
		ASM 134S F132	MV 505771
		Declaration of materials	MD 51.023

Accessories

- 0313529 001*** Split-range unit, 0...10 V, for setting sequences; to be fitted and connected in separate distribution box
- 0361977 001** Assembly kit for MH32 / MH42 control valve; [MV 505477](#)
- 0370059 000*** Clamp-on lever for shafts of d=8-18 mm
- 0370990 001*** Auxiliary change-over contacts ⁴⁾ single; [MV 505446](#)
- 0370990 002*** Auxiliary change-over contacts ⁴⁾, double; [MV 505446](#)
- 0370992 001*** Potentiometer, 2000 Ω, 1 W; [MV 505446](#)
- 0370992 002*** Potentiometer, 130 Ω, 1 W; [MV 505446](#)
- 0372200 001** Fixing bracket; [MV 505676](#)
- 0372201 001** Spindle extension with coupling; [MV 505676](#)
- 0372202 001** Lever & tape; [MV 505676](#)
- 0372203 001** Connecting piece for contact unit; 0370990; [MV 505676](#)
- 0372204 001** Spindle for clamp-on lever 0370059; [MV 505676](#)

^{*)} Dimension drawing or wiring diagram are available under the same number

- 1) Also for 2-point or 3-point depending on type the of connection
- 2) 24 = for input signal 0...10 V only
- 3) Maximum angle of rotation: 95° (without stops)
- 4) Fully variable from 0...90°; max. loading 5 (2) A, 24...230 V
- 5) Version with halogen-free cable available on request

Operation

Depending on how it is connected (see wiring diagram), the actuator can be used as a continuous 0...10 V, as a 2-point (open/close) or as a 3-point drive (open/stop/close) with intermediate position. The running time can be matched to requirements using switches S1 and S2. Manual adjustment by turning the spindle adaptor after de-coupling the gears (button on housing cover)

Connected as a 2-point control unit

Open/close activation can be effected via two wires. Power is applied to the drive via the blue and the brown wires. On connecting power to the black wire (2b), the damper drive moves to the end position. When power is switched off, the drive goes to the opposite end position (clockwise direction to 100% angle of rotation).

The unused red and grey wires should not be connected, nor should they come into contact with other wires. We recommend that you insulate them.

Connected as a 3-point control unit

By connecting power to the wires (2a or 2b), the damper drive can be moved to any position. Angle of rotation (as viewed from the actuator towards the spindle adaptor):-

- The spindle adaptor turns in a clockwise direction if power is applied to the black wire (2b).
- The spindle adaptor turns in an anti-clockwise direction if power is applied to the brown wire (2a).

In the end positions (the damper's end position; the end position due to the angle-of-rotation limit; on reaching the maximum angle of rotation of 92°) or in the event of an overload, the electronic motor cut-off responds (no end switches). The direction of rotation can be changed by transposing the connections.

The unused red and grey wires should not be connected or come into contact with other wires. We recommend that they be insulated.

Connections for control voltage 0...10 V

The integrated positioner controls the drive as a function of the controller's positioning signal y.

Angle of rotation (as viewed from the actuator towards the spindle adaptor):-

Direction of operation 1 (mains power at brown wire, internal connection 2a): the spindle adaptor turns in a clockwise direction as the positioning signal rises.

Direction of operation 2 (mains power at black wire, internal connection 2b): the spindle adaptor turns in an anti-clockwise direction as the positioning signal rises.

The starting point and the control span are both pre-set.

Either the brown or the black wire should be connected, depending on the direction of operation. The unused wire should be insulated.

After power has been applied, the stepping motor moves to both stops one after the other and determines its effective angle of rotation (always with a running time of 60 seconds). Thanks to the electronics unit, no steps are lost, and the drive needs no periodical re-adjustment. After manual adjustments have been made, or when there is a power failure lasting longer than 5 minutes, the drive re-adjusts itself automatically. Whenever the angle of rotation is altered, a re-adjustment must be initiated (by manual adjustment) so that the drive, the control voltage and the feedback signal can adapt themselves to the new angle of rotation. Initialisation can be switched off using switch S3. The actuator then always uses the stops that were last saved. If it detects a new stop, it saves it, and the feedback signal is adapted accordingly. After an interruption to the power supply lasting longer than 5 minutes, the actuator works (without initialisation) from the current position. The current positioning value is issued as a feedback signal, until the drive moves to a stop and the current position can be calculated and issued.

If the control signal (0...10 V) is interrupted and direction of operation 1 is set, the damper closes fully (0% position).

Coding switch

ASM 124S Running time [sec]	ASM 134S Running time [sec]	S1	S2	S3
120s	240s	off	on	–
120s	120s	on	on	–
60s	120s	on	off	–
60s	240s	off	off	–
Initialisation on		–	–	on
Initialisation off		–	–	off
Ex-works position		on	on	on

Split-range unit, accessory 361529 001

The starting point U_0 and the control span ΔU can be set using the potentiometer. This makes it possible to activate several regulating units in sequence or in cascade using the controller's control signal. The input signal (partial range) is amplified into an output signal of 0...10 V. This accessory cannot be fitted in the drive, but should be located externally in an electric distribution box.

Engineering and fitting notes

The combination of stepping motor and electronics allows several air dampers with different torque levels to be run in parallel, if drives of the same SUT type are used. The actuator can be mounted in any position, can be inserted directly onto the damper shaft and is fixed using the self-centring clamp. The damper spindle is turned by the self-centring spindle adaptor, which reduces the stress on the bearings. N.B.: The housing should not be opened.

The coding switches are accessible via an opening with black lid in the housing cover.

The following accessories can be fitted to each actuator: one set of single auxiliary contacts or one set of double auxiliary contacts or one potentiometer. On the ASM 134, this type of accessory cannot be fitted if the length of the damper spindle is <52mm. By re-positioning a disc under the coupling piece, the angle of rotation can be limited between 0 and 90° in steps of 5°. The coupling piece on the ASM 124 is suitable for damper spindles of \varnothing 10...20 mm and \square 10...16 mm. The coupling piece on the ASM 134 is suitable for damper spindles of \varnothing 12...20 mm and \square 10...16 mm.

Fitting outdoors. If the devices are fitted outdoors, we recommend that additional measures be taken to protect them against the effects of the weather.

Additional technical data

The upper part of the housing, with the lid, manual-adjustment knob and the cap, contains the stepping motor and the SUT electronic control unit. The lower part contains the maintenance-free gears and the spindle adaptor.

Auxiliary change-over contacts

Switch rating: max. 250 V a.c.; min. current 20 mA at 20 V

Switch rating: max. 30 V d.c.; min. current 1 mA at 4 V d.c.

Power consumption:

Type	Running time s	Condition	active power P W	apparent power S VA
ASM 124S F132	60	Operating	2.4	4.4
		Standstill	0.25	0.46
ASM 134S F132	120	Operating	2.4	4.3
		Standstill	0.26	0.48

CE conformity

EMC directive 89/336/EEC

EN 61000-6-1

EN 61000-6-2

EN 61000-6-3

EN 61000-6-4

Machine directive 98/37/EEC (II B)

EN 1050

Dimension drawing

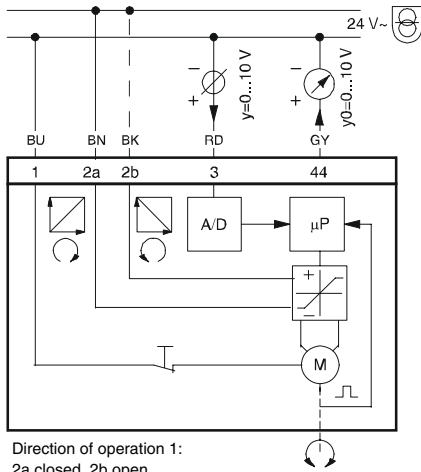

Direction of operation 1:
2a closed, 2b open
Direction of operation 2:
2b closed, 2a open

Variante 1 (3pt)

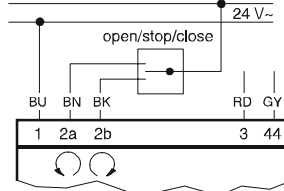

RD = red
BN = brown
BK = black
BU = blue
GY = grey

Variante 2 (2pt)

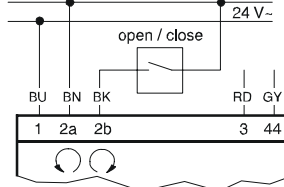

A09681e

Wiring diagram

ASM 124: Ø 10...20 mm
10...16 mm
ASM 134: Ø 12...20 mm
10...16 mm

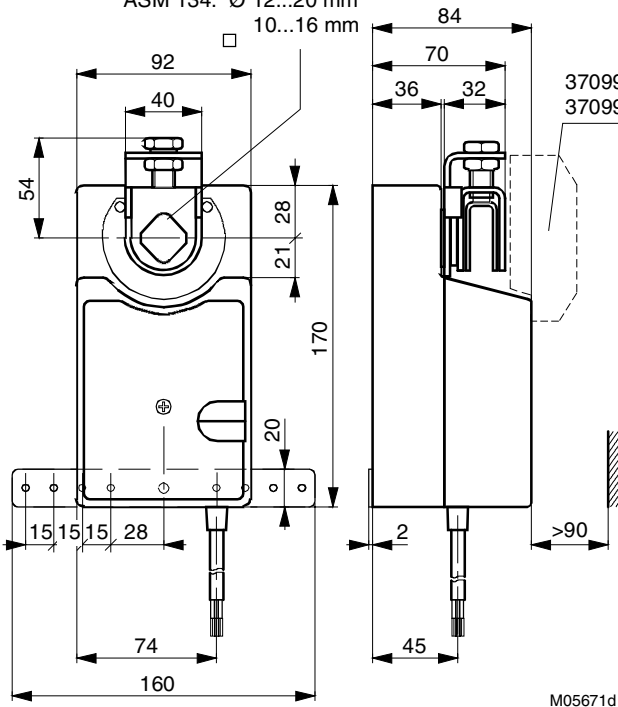

M05671d

Accessories

370990/001

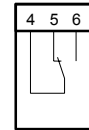

A01360a

370990/002

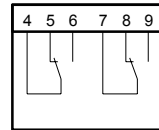

A01361a

370992/...

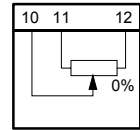

A01363

370059

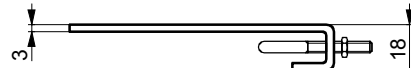
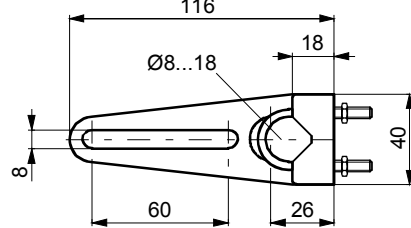

M00297b

313529

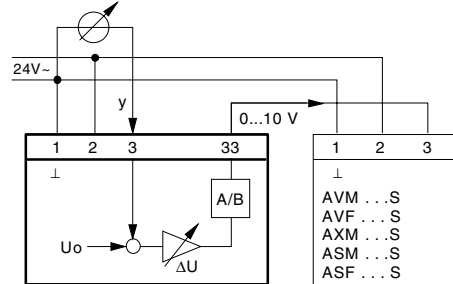

A09421a