

TFC: Frost-protection monitor with capillary-tube sensor

Used for the monitoring of temperature in air heaters (air side), water pipes and ducts. Especially suited for installations where vibrations occur.

Splash-proof housing of light metal for wall mounting; transparent, impact-proof, thermoplastic cover; separate (sealable) settings for upper and lower switching points; capillary-tube sensor of copper (6 m long); guide sleeve and 5 holders for fitting the capillary-tube; shake-proof snap-action switch with single-pole change-over, gold-plated silver contacts; screw terminals for wire of up to 2.5 mm²; cable inlet for Pg 13.5.



T03417

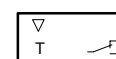

Y03243

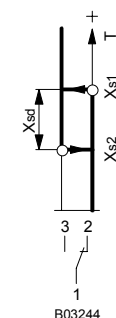

B03244

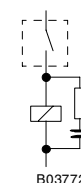

B03772

Type	Setting range [°C]	Min. switching difference ¹⁾ [K]	Permissible sensor temp. [°C]	Weight [kg]
TFC 7B12 F001	0...15	2...3	-40...180	0.9
Contact rating			Perm. ambient temp.	0...70 °C ⁴⁾
as silver contacts ²⁾ for higher loading			Degree of protection	IP 44 (EN 60529)
max.	10(2) A, 400 V~		Protection class	I (IEC 60730)
	25 W, 250 V=			
min.	100 mA, 24 V		Wiring diagram	A01497
as gold contacts ³⁾ for lower loading			Dimension drawing	M259249
max.	200 mA, 50 V		Fitting instructions	MV 23158
min.	1 mA, 6 V			
Time constant				
in air 0.3 m/s	35 s			
in water 0.5 m/s	2 s			

Accessories

- 0044529 000** Plug spanner for the setting screws
0233310 000 Aluminium cover with window (with accessory 0259299 000 = IP 54)
0259189 000* Bracket for off-wall mounting
0259299 000 Cable screw fitting Pg 13.5
0259409 000* Bracket (for 3-point fixing when used with 0259189)
0303167 000* Five holders for capillary tube

^{*}) Dimension drawing or wiring diagram are available under the same number

- 1) The small values apply to the high setting points, the large values to the low ones.
- 2) If under inductive load, take RC circuit into account.
- 3) If the contacts are ever loaded higher than 200 mA, 50 V, the gold plating will be damaged. The contacts are then classed only as silver contacts, since they lose the properties of gold contacts.
- 4) The head of the instrument must be fitted at a place which is warmer than that of the sensor.

Operation

Whenever the temperature exceeds the upper switching point (which can be set on the right-hand scale), the contacts switch over from 1-2 to 1-3.

When the temperature falls below the lower switching point (which can be set on the left-hand scale), the contacts switch over from 1-3 to 1-2.

The vibration-proof snap-action switch has a pre-loaded spring which prevents the change-over mechanism from operating until the switching point has been attained. This ensures that the contacts remain fully closed right up to the switching point, even if operation is very slow.

Technical notes

RC circuit under inductive load

For the optimum RC circuitry, refer to the specifications supplied by the manufacturers of the relays, contactors etc. If these are not available, the following rule of thumb can be applied in order to reduce the inductive load:-

- Capacitance of the RC circuit (μF) is equal to or greater than the operating current (A).
- Resistance of the RC circuit (Ω) is approx. equal to the resistance of the coil (Ω).

Additional technical data

Complies with:-

Directive 73/23/EEC	EN 60730-1/ EN 60730-2-9
EMC directive 89/336/EEC	EN 61000-6-1/ EN 61000-6-2
	EN 61000-6-3/ EN 61000-6-4

Wiring diagram

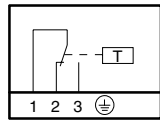

A01497a

Dimension drawing

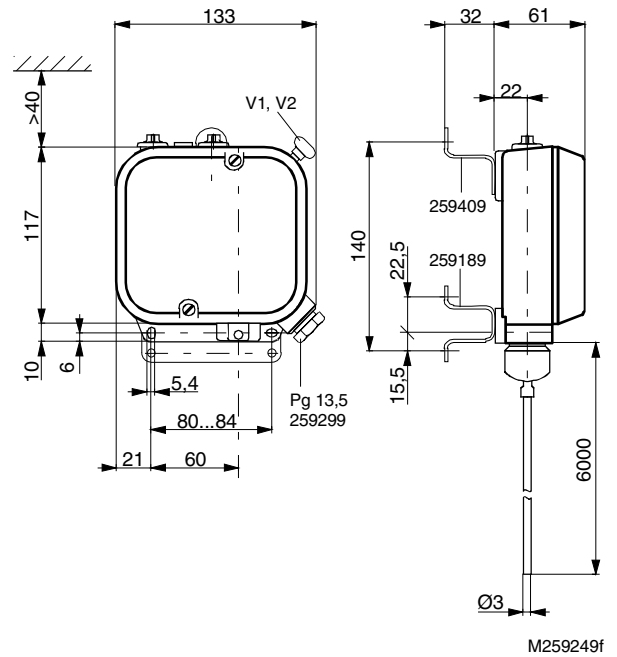

Accessories

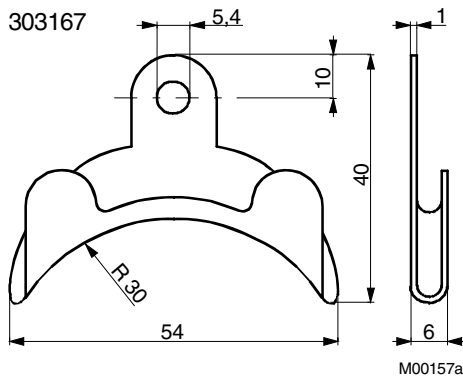

M00157a

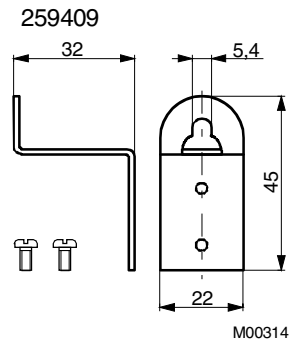

M00314

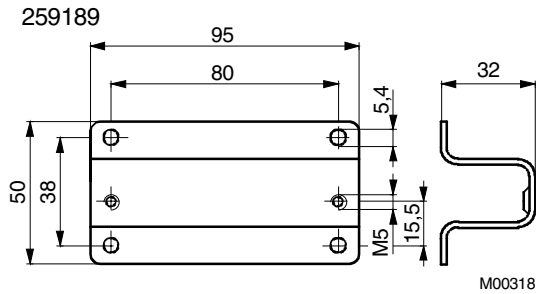

M00318